

Cable Ring for 800W / 700W rack, pack of 10

- Size : 88 x 180 mm
- Rigid structure
- Material : Steel
- Positioned on the front

Part no. : CMR-180P

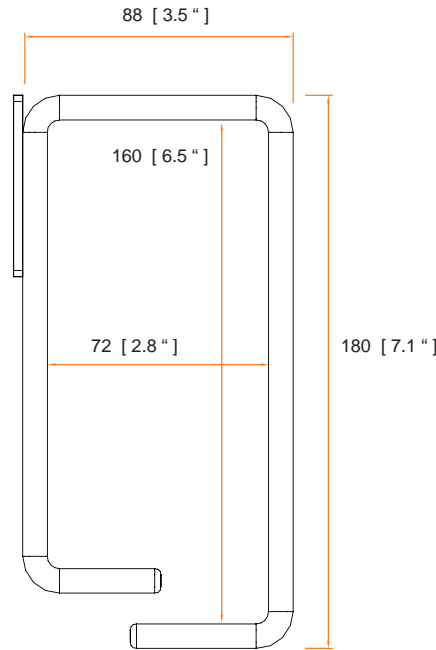

Hardware set : Cable ring x 10
M6 screw & nut x 20

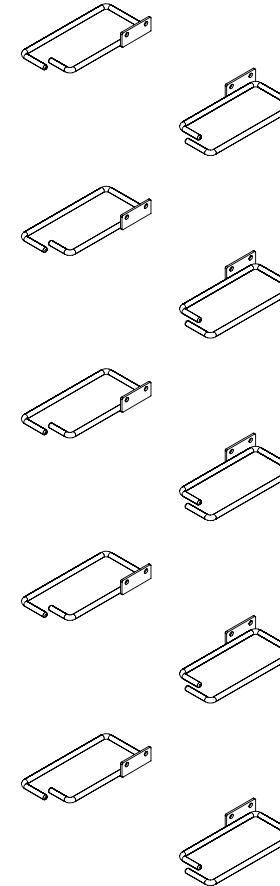

unit : mm / in.

The company reserves the right to modify product specifications without prior notice and assumes no responsibility for any error which may appear in this publication.

Copyright 2015 Austin Hughes Electronics Ltd. All rights reserved.



Design. Manufacturing. Global Services.

Material : Steel
Hardware set : M6 screw & nut x 20
Color : Black (RAL - 9005)
Gross weight : 2.2 kg / 4.84 lb
Environmental : RoHS2 & REACH compliant by SGS



REACH